

AAMA Window Selection Guide

Robert Tellez

Roberts Consulting Group

San Diego, Ca. 91941

1-619-713-2024

www.RobertTellez.com

The American Architectural Manufacturers Association (AAMA) is a trade association of firms engaged in the manufacture and sale of architectural building components and related products.

Tracing its origins back over 50 years, AAMA is active in its role as the “Technical Information Center” for the industry’s products.

These include windows, sliding glass doors, storm windows and doors, curtain walls, store fronts, skylight and space enclosures, siding and related products.

• DESIGN CONSIDERATIONS

General

- *Protection of building occupants from rain, heat, cold, insects, vandals, etc" is a basic function of the total window system.*
- *The window, when closed, must have adequate strength to resist wind loads and must properly seal to prevent wind and water penetration.*
- *It should have insulating properties to protect from heat and cold.*
- *It should be capable of being locked to resist forced entry and, where conditions require it, be glazed with materials and have features which will resist vandalism.*

The window system, must act as a filter, permitting transmission of desirable elements between the indoors and outdoors while protecting the indoors from the entrance of undesirable outdoor elements.

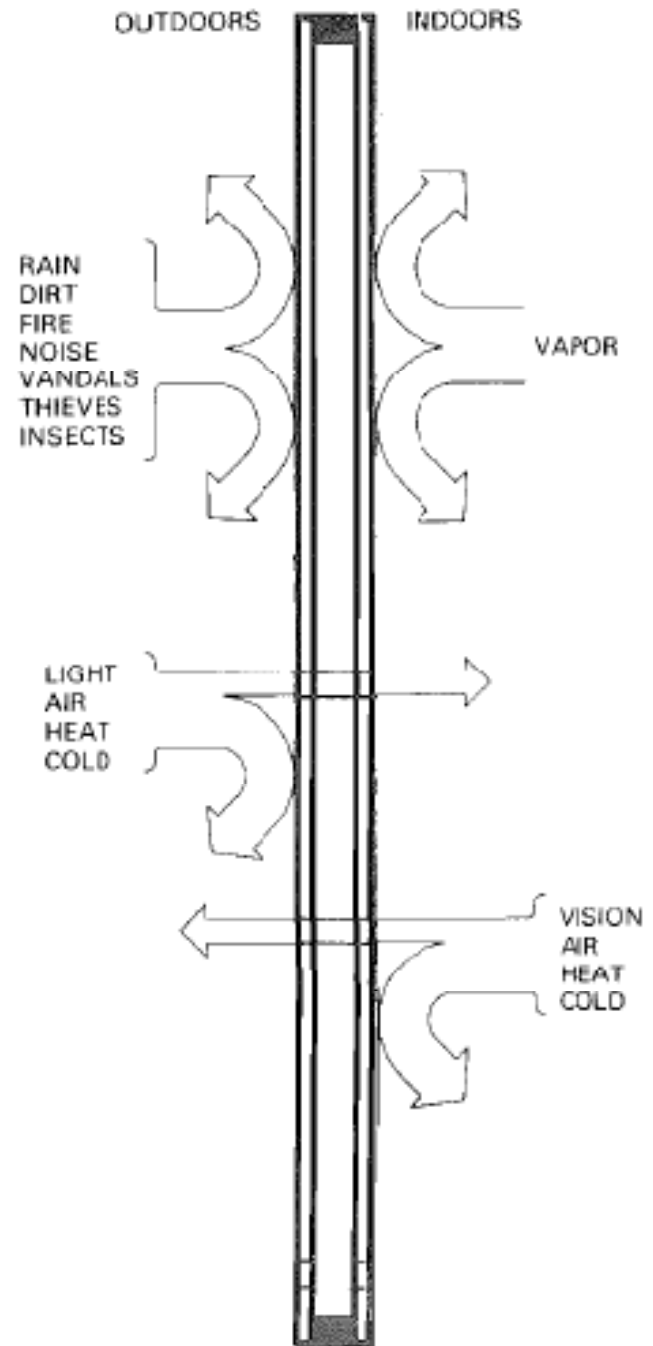

Psychological

- Humans desire a view of the outside, even a mundane view is preferable to no view.



Psychological

- The amount of glass used in buildings is indicative of that desire.
- The challenge is to maintain a view while satisfying all other the other wall functions an window must provide (structural, thermal, air & water resistance, etc)



Structural

- Wind loads are the principal loads which windows must resist.
- Wind loads basically determine the structural design of the window.

- *A knowledge of the wind velocities to which the walls and windows of a building will be subjected is essential to specifying the design pressure for the window.*
- *When wind blowing at a given velocity encounters an obstruction such as a building wall, the kinetic energy applies a wind load pressure against the wall.*
- *The pressure is often simply referred to as velocity pressure.*

Wind pressure varies across the facade

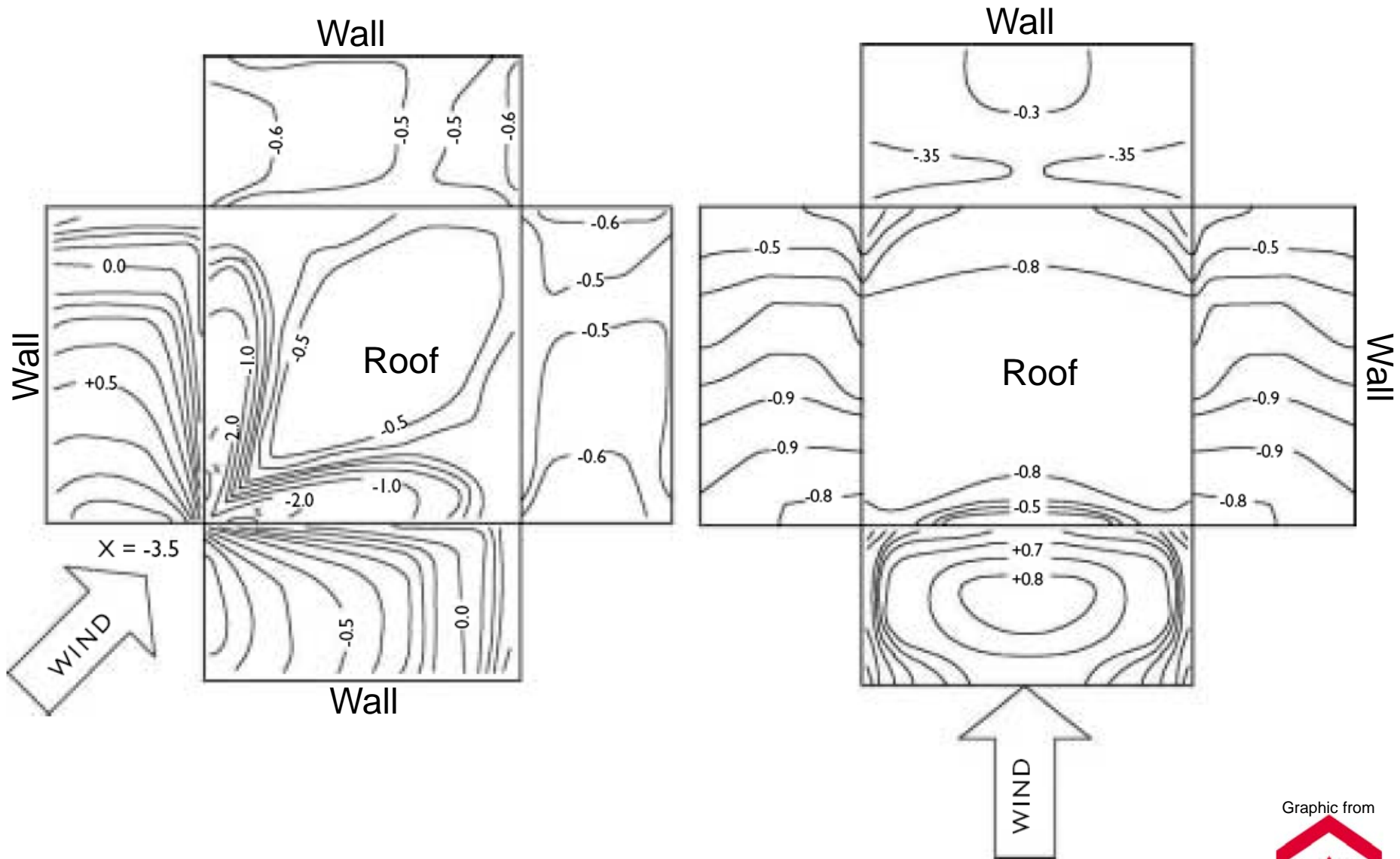

Wetting patterns vary with wind pressure

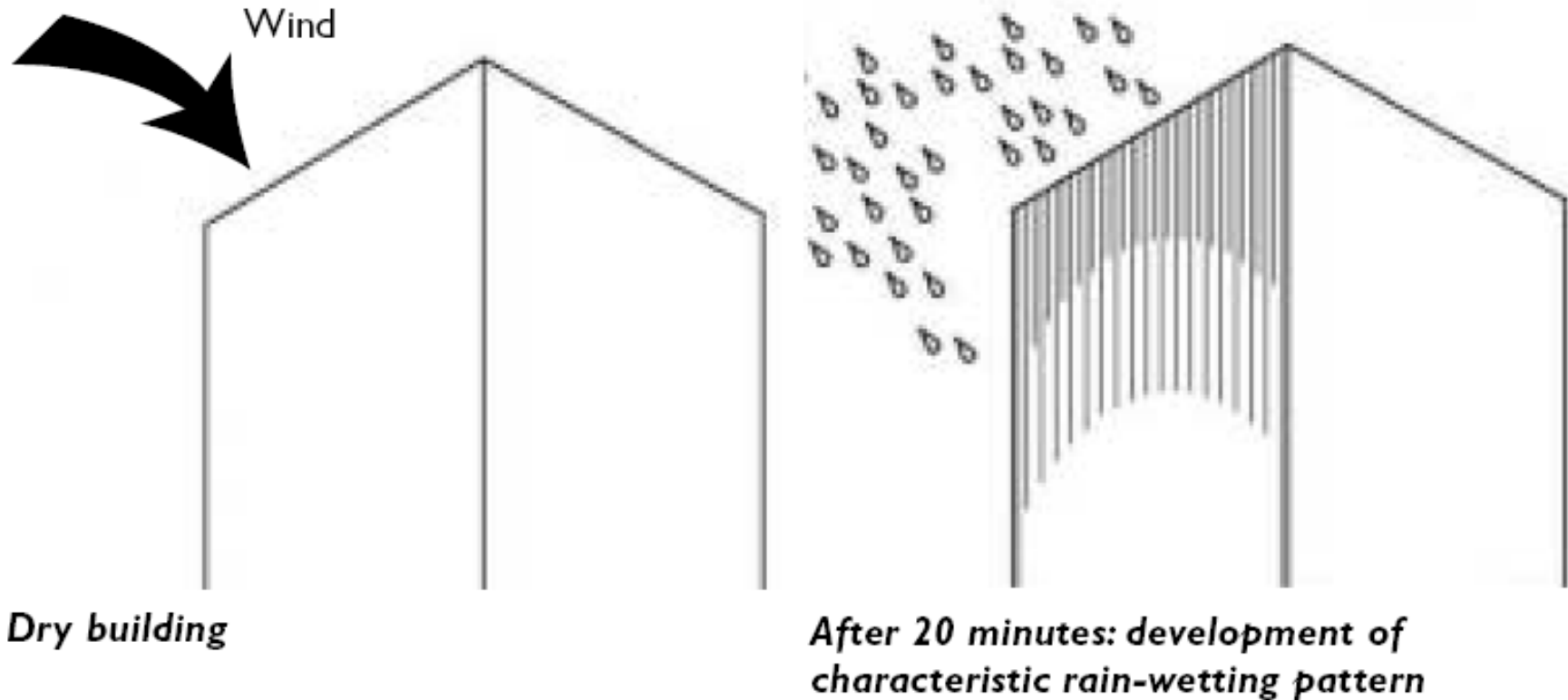

- *The recommended references for wind loads on buildings are:*
- *ASCE 7-05 and AAMA TIR-A10.*

- *Wind velocities for a particular geographical area may be taken from the National Weather Services basic wind speed maps.*
- *The Isotachs on these maps show the annual extreme fastest mile speed recorded for a 25-, 50-, or 100-year recurrence interval.*

The velocities generally used for window design are those from the 50-year recurrence map

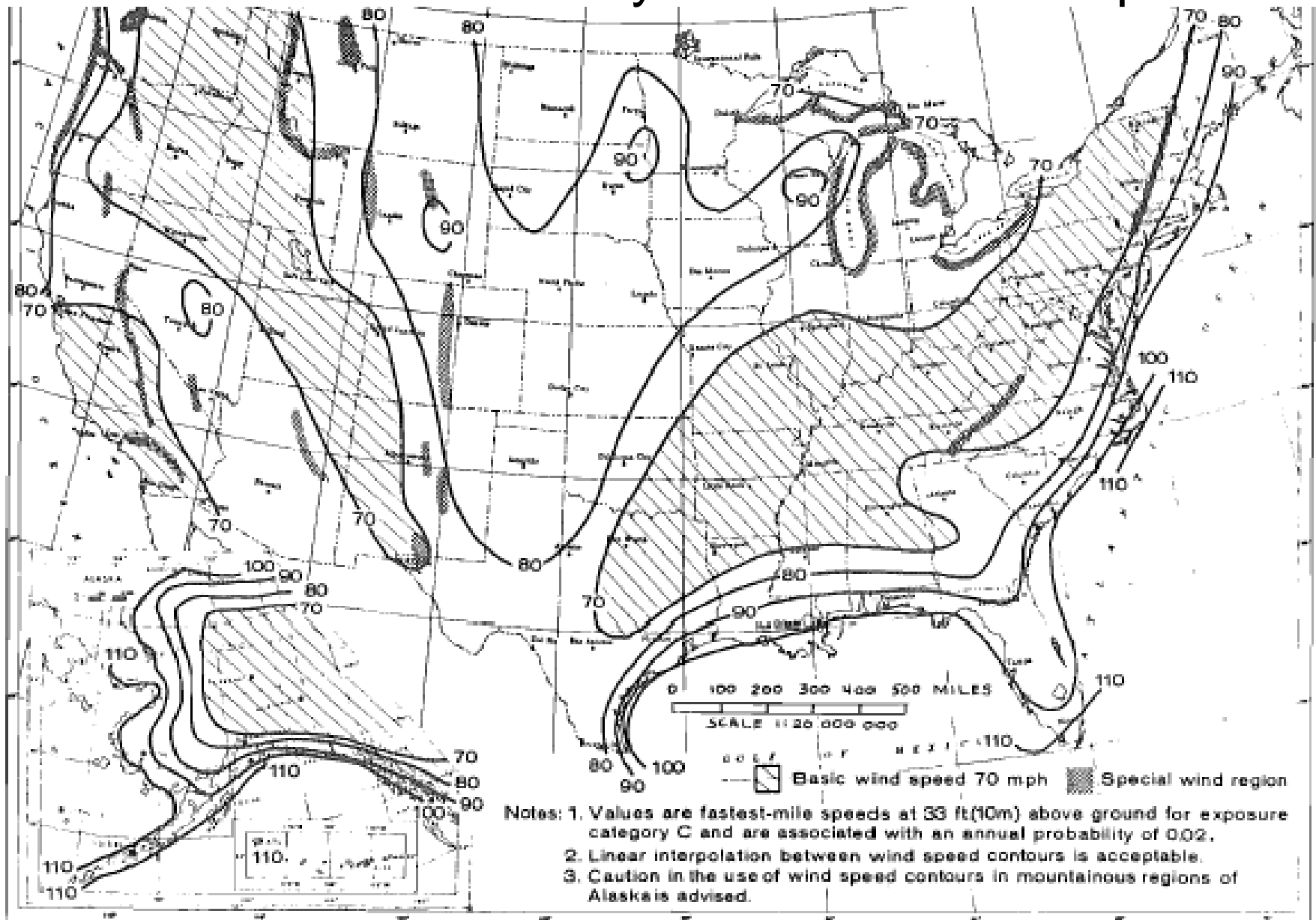

The four different terrain conditions are as follows.

- **Exposure A** - *Large city centers with at least 50% of the buildings having a height in excess of 70 feet.*
- **Exposure B** - *Urban and suburban areas, wooded areas, or other terrain with numerous closely spaced obstructions having the size of single-family dwellings or larger.*
- **Exposure C** - *Open terrain with scattered obstructions having heights generally less than 30 feet. This category includes flat, open country and grasslands.*
- **Exposure D** - *Flat, unobstructed coastal areas directly exposed to wind flowing over large bodies of water.*

• Wind velocity at any location increases with the height above the ground. The velocity at any height on a building will depend on the type of terrain.



- Design pressures for buildings may also be determined by boundary layer wind tunnel testing.
- This procedure is recommended for buildings with unusual shape, size, height, or location.



•Note ASCE 7-05 is only applies to rectangular buildings.

- *AAMA recommends that windows be structurally tested in accordance with ASTM E 330-02 at a pressure equal to 1.5 the design pressure.*
- *This represents the safety factor which is required of all windows which meet AAMA voluntary standards.*

Maps of Recent Earthquake Activity in California-Nevada

- Anticipated seismic loads also affect the structural design of the window.

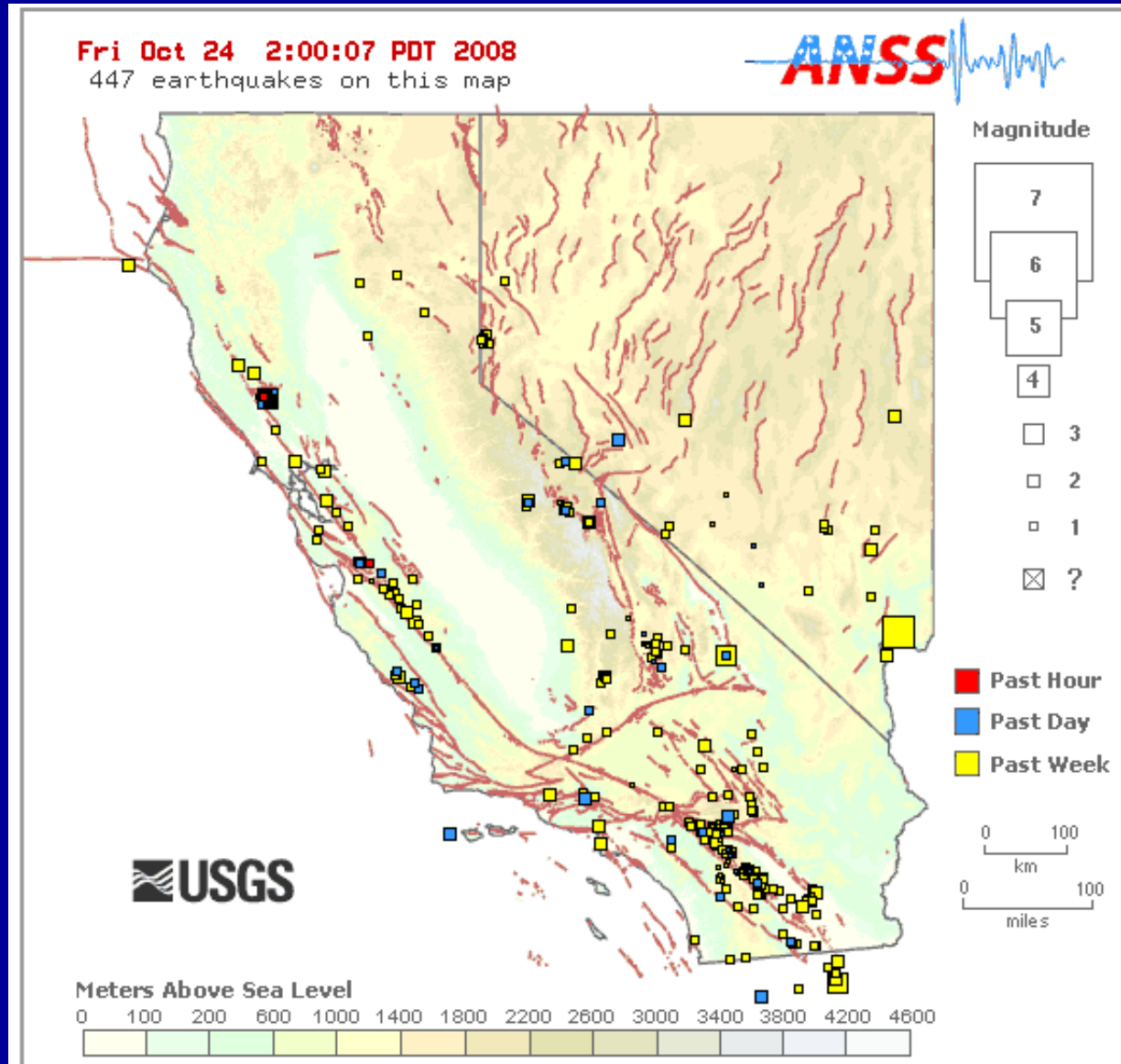

ASCE 7-05 makes the following recommendations for the connections and joints of windows or panels:

1. They shall have sufficient ductility and rotation capacity to preclude fracture or brittle failures at or near connections.
2. To permit movement for story drift in the plane of the window or panel, a sliding connection using slotted or oversize holes may be used, or a connection which permits movement by bending of a ductile material may be used.
3. They shall allow for a relative movement between stories of not less than two times story drift caused by wind or seismic forces, or $\frac{1}{4}$ inch, whichever is greater.

Water Resistance

- One of the most important functions of a window is its ability to resist the penetration of rain. It is the lack of ability to perform this function adequately that results in more complaints about windows than any other item. Carpeting, interior furnishings, and even walls, ceilings and flooring may be seriously damaged by water leakage. Therefore, it is imperative that the architect consider this matter thoroughly when establishing the requirements for windows.

- As in the case of determining structural requirements for windows, the wind velocities in the geographical location of the building, the terrain and the height of the building enter into the determination of the specifications for resistance to water penetration. The high-rise condominium on the beach, facing the ocean, will be subjected to wind and rain conditions more severe than conditions of wind and rain affecting a single-family house located in a hilly, wooded town.

- Wind imparts velocity to the rain and creates a pressure difference across the wall. It is the combination of the driven rain striking the window and the pressure difference across the window that tends to force the water through the seals between the operating sash or ventilator and frame and through adequately sized drainage slots or weep-holes.

- The most effective way to protect against water penetration is to provide a pressure equalized design. In such a design, the space between the operating unit and the frame is equalized with the outside pressure generally by means of drainage
- slots or weep-holes, as shown in Figure 3.

Figure 3. Pressure-equalized design

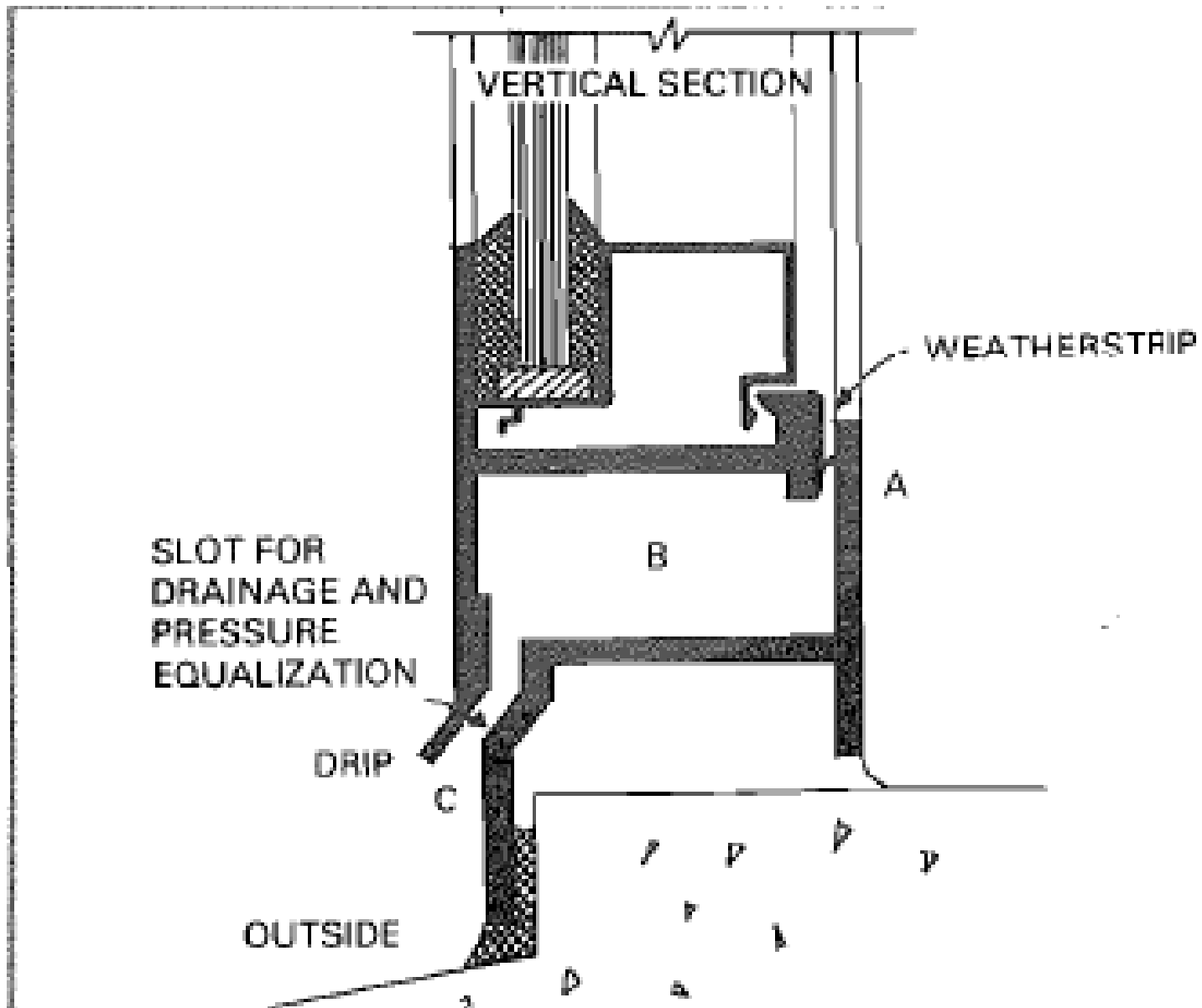

- With the pressure equalized there is no force tending to push water through the seals. The weep-holes must be baffled or otherwise protected to prevent the direct entrance of the driven rain. The seals on the outer side of the windows act primarily as rain baffles while the seals on the inside act as air seals.

- Wind may be defined as air in motion. According to the laws of physics, when air moving in a horizontal direction at a certain velocity strikes a stationary vertical plate, it will exert a static pressure on the plate.
- Wind is a major contributor to Primary Water Intrusion, with respect to all weather exposed components.

- Moving air striking a vertical plate is equivalent to wind blowing against a window. What the equation says is that a 10-mph wind can exert a pressure of 0.256 psf whereas a 100-mph wind can exert a pressure of 25.6 psf. The significance of these pressures becomes apparent when we relate them to the height to which they will raise water. We refer to this height as *water head*.

- The relationship between pressure and *water head* is given by the equation below:

- This is graphically shown in Figure 4. A Pilot tube connected to a water manometer and directed into a 50-mph wind will cause the water column in the manometer to rise 1.23 inches. If a window in which pressure equalization has not been, or cannot be, incorporated is to resist the penetration of rain driven by wind at a certain velocity, the sill and its upstanding leg must be designed to accommodate the water head resulting from this velocity.

Figure 4. Water head.

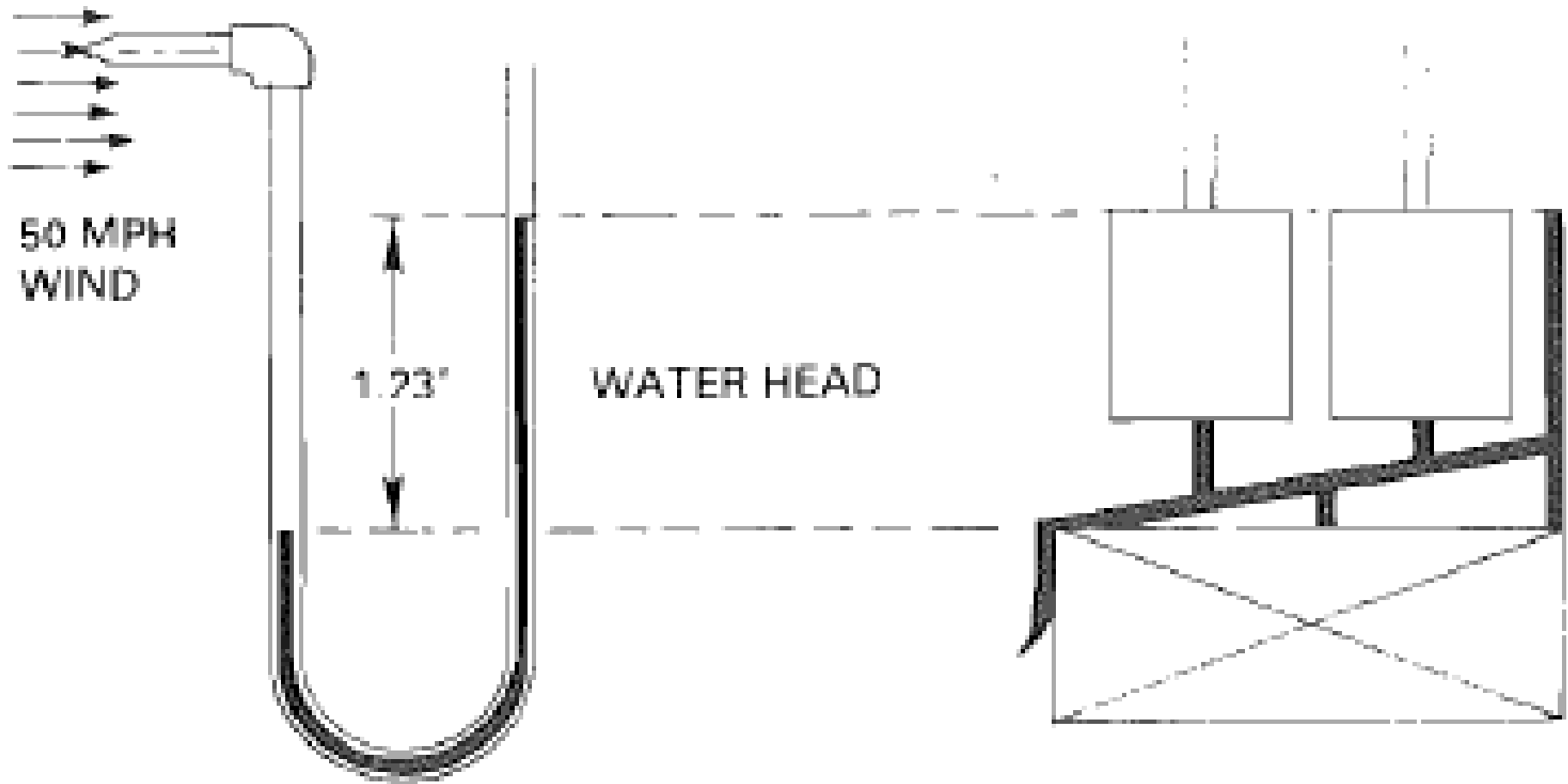

- In addition to the static pressure created across an opening by wind, there are other forces which move water through an opening.

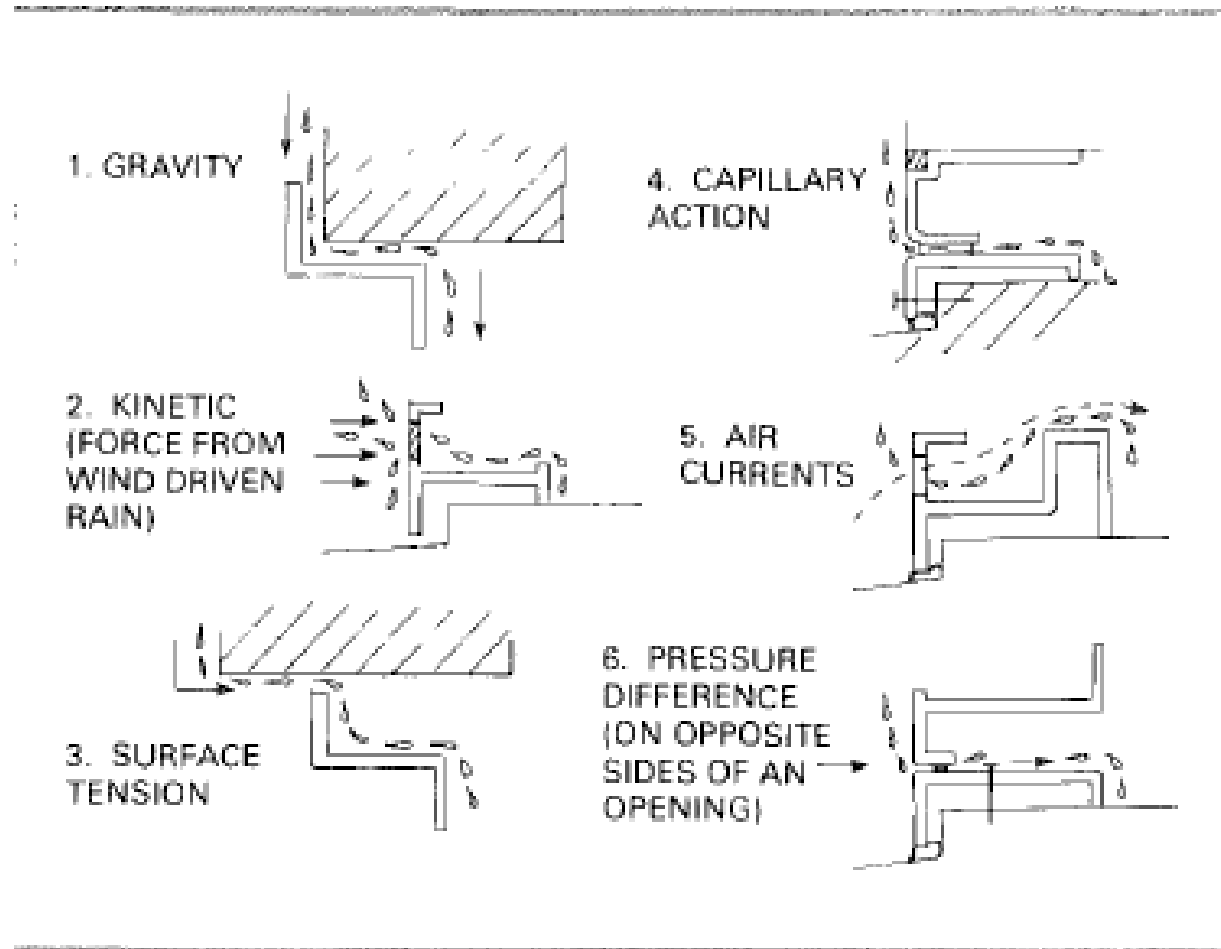

Performance Classes

ANSI/AAMA 101 ALUMINUM AND VINYL PRIME WINDOWS

CLASSIFICATIONS, DESIGNATIONS AND PRODUCT SYMBOL SYSTEM								
Product Type		Grade		Performance Class				
Product Code	Product Description	Designation	Description	Class (Design Pressure)	R	C	HC	A
A	Awning	R	Residential	15	X			
C	Casement	C	Commercial	20	X	X		
DA	Dual Action	HC	Heavy Commercial	25	X	X		
DH	Double (Single Hung)	A	Architectural					
F	Fixed			30	X	X		
GH	Greenhouse			35	X	X		
HS	Horizontal Sliding			40	X	X	X	X
J	Jalousie							
P	Projected			45	X	X	X	X
SD	Side Hinged (Inswinging)			50	X	X	X	X
TH	Top Hinged							
VP	Vertical Pivoted							
VS	Vertical Sliding							

Designation	Min. Test Size (Double Hung)		Min. Design Pressure (psf)	Min. Structural Test Pressure (psf)	Min. Water Resistance Test Pressure (psf)
R	3'8"	x 5'10"	15	22.5	2.86
C	4'5"	x 7'6"	20	30.0	3.00
HC	5'6"	x 10'0"	40	60.0	6.00
A	5'6"	x 10'0"	40	60.0	6.00

AAMA Performance class (rating from low to high performance):

- **R** **Residential**
- **LC** **Light Commercial**
- **C** **Commercial**
- **HC** **Heavy Commercial**
- **AW** **Architectural**

Most common classes for Low-Rise Frame buildings:

- **R Residential (single family)**
- **LC Light Commercial (low-rise multi-family)**
- **C Commercial (retail/hotels)**

- Base selection criteria on code design for wind loads (**ASCE 7-05**) to determine required design {wind} pressure (DP) measured in psf
- **DP = Design {wind} Pressure**

Minimum DP ratings for AAMA performance classes & grades:

AAMA Class	DP	AAMA Grade
R	15 psf	15
LC	25 psf	25
C	30 psf	30

AAMA rates windows & doors for:

- Air Infiltration
 - Structural load capacity
 - Water Penetration Resistance
-
- ***WATER IS THE MOST IMPORTANT !***

Water Penetration Resistance is tested

- Water Penetration Resistance Test pressure (WTP) is based on a % of the Design Pressure (DP)

- **WTP = ___% DP**

Windows and doors are classified by their WTP

- AAMA designates typical WTP at 15% (.15) of DP (*except where wind+rain occur at once = 20 %*)
 - **WTP = .15 DP**

The WTP also corresponds to wind speed

AAMA Class	WTP	Windspeed
15	2.86 psf	33 mph
25	3.75 psf	38 mph
30	4.50 psf	42 mph
40	6.00 psf	48 mph

**Same door,
different
sill height,
different
rating**

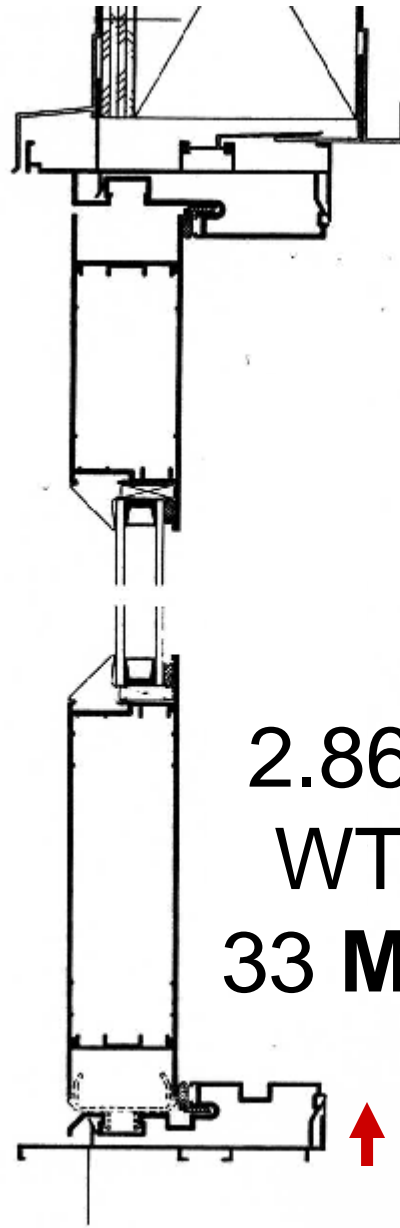

**2.86 lb
WTP,
33 MPH**

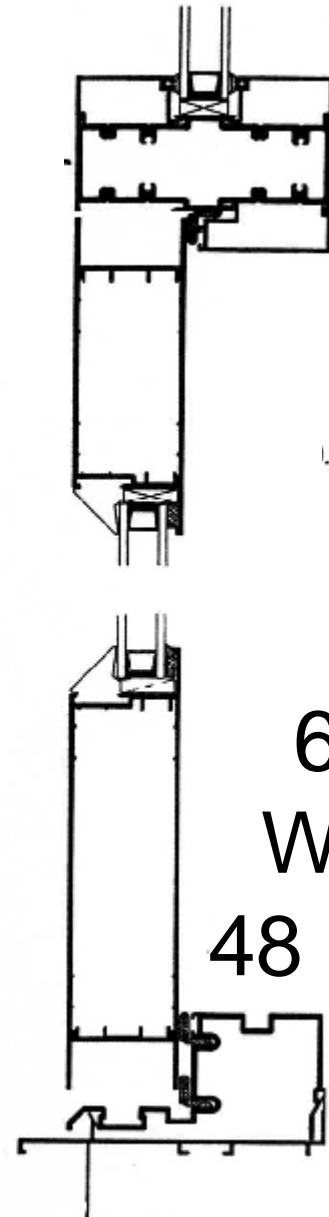

**6 lb
WTP,
48 MPH**

Periodic weather conditions can exceed product performance. Local wind speeds can exceed unit rating

- AAMA rated products may leak during extreme local weather conditions



AAMA Test Standards

- AAMA test standards assume that rains usually occur without winds
- Do NOT accept AAMA presumption that wind & rain don't happen at the same time – check your site

Kinetic Energy

- Many locations experience wind + rain at wind gusts > 50 mph

R30 & LC30 grades only = 42 mph

- Research local rain history and weather exposed directions

Be aware of local microclimates

- Wind direction & gusts
- Periods of sustained wetness
- Wind + rain combine
- Weather–exposed locations



What is a leak ? What is not a leak ?

- An AAMA defined “not a leak” may be unacceptable to consumers:
 - Water sitting in the sill track
 - Water on top the sill
 - Water draining down the inside of the interior glass

What is a leak?

- Not a leak?



- Leak



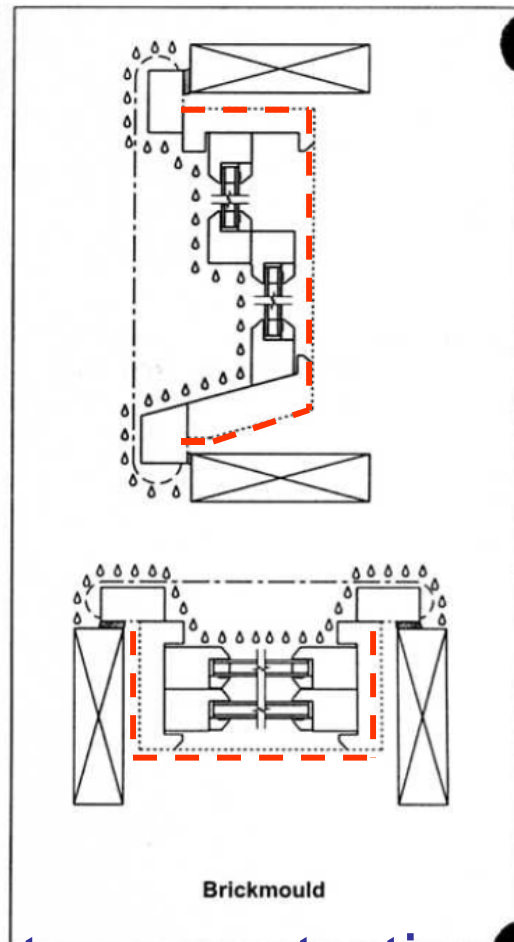
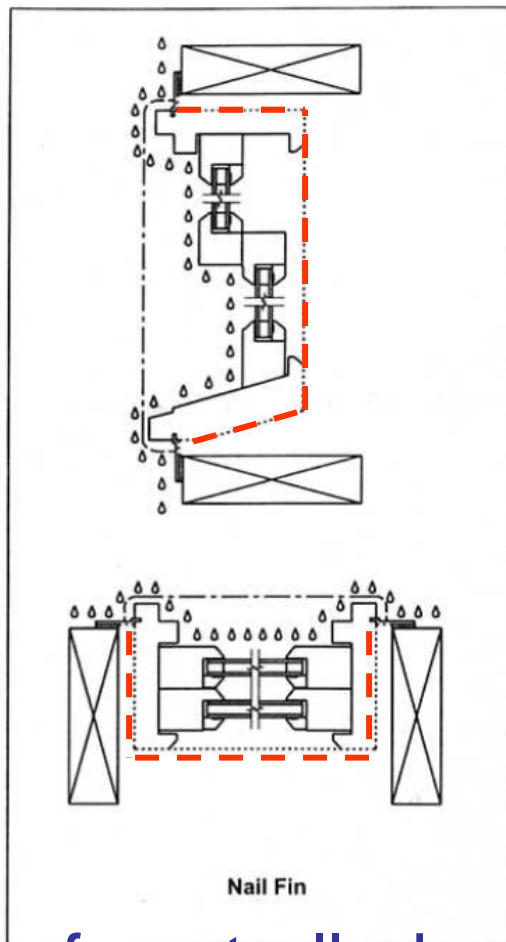
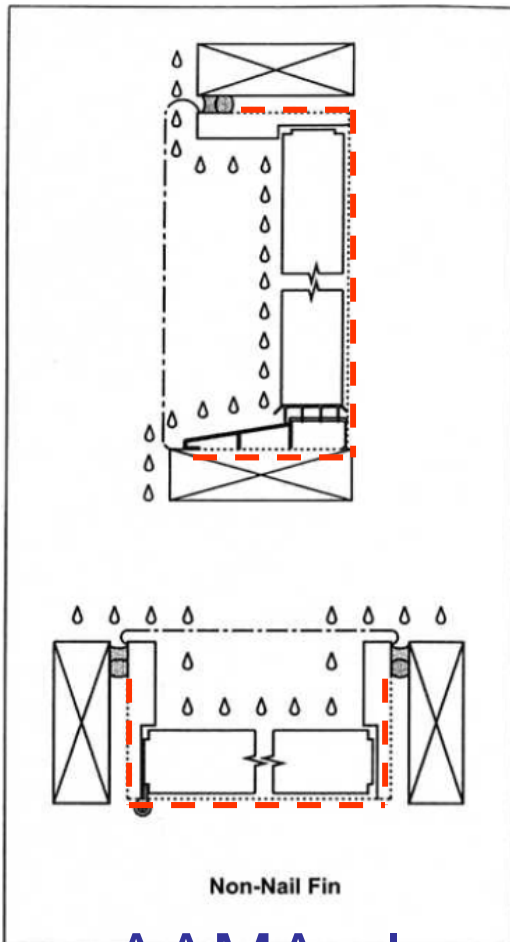

AAMA plane of controlled water penetration

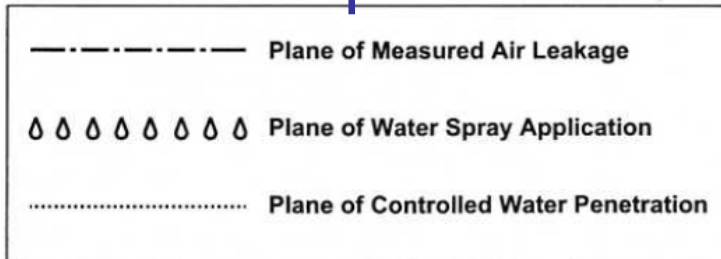

Air leakage is measured at the exterior seal line of the assembly. Air leakage through the test fixture and the perimeter seal is excluded. The water spray is applied to the exterior of the assembly and its juncture with the test fixture. The plane of controlled water penetration is defined as the innermost plane of the test assembly. This does not include the interface between the rough opening and the frame.

AAMA label

- AAMA/WDMA/CSA 101/I.S.2/A440-08

(2008) replaces

- AAMA/WDMA/CSA 101/I.S.2/A440-05

(February 2005) replaces

- ANSI/AAMA/WDMA 101/I.S. 2/NAFS-02

(March 2003) replaces

- ANSI/AAMA/NWDA 101/I.S. 2-97.

(March 1997)

AAMA label

- Each AAMA unit with certification label:
Performance class & grade.



Air Leakage

- Excessive air leakage causes drafts and discomfort to building occupants.
- In recent years, the rapidly escalating price of energy has put much greater emphasis on the need to control air leakage. Leaky windows can be a major source of energy loss in a building.

- Air leakage, both infiltration and exfiltration, is caused by wind; by internal positive or negative pressures developed by the heating, ventilating and air conditioning system; and by stack action.
- In the winter, cold outside air, being heavier than warm inside air, infiltrates into the lower spaces of a building, pushes the lighter inside air up and causes exfiltration from the upper spaces. This is stack action, and for large, high-rise buildings in cold climates, its effect can be very significant.
- Wind, HVAC system and stack action effects must be taken into account in selecting a window that will best meet the requirements of the building.

Heat Transmission

- Windows transmit heat through conduction, convection, radiation and air leakage.
- Through careful consideration of all these factors in the building design, the energy efficiency of a building can be optimized.
- It now becomes a matter for the designer to control the heat transmission due to heat conduction through the window, convection due to air currents on both the inside and outside surfaces, heat gain due to solar radiation, and energy loss due to air leakage.

- When there is a temperature difference across a window, heat will flow from the high temperature side of the window to the low temperature side.
- During the winter, heat will flow from the warm inside air to the cold outside air.
- During the summer, heat will flow in the opposite direction.
- Heat flow due to temperature difference is referred to as conductive heat flow. The rate of conductive heat flow from air to air through a window is determined by the thermal resistance of the glass and framing material plus the air film resistance at the inner and outer surfaces of the glass and framing.

- In the case of single glass, the resistance to heat flow is due almost entirely to the resistance at the surfaces.
- This resistance from surface to air depends on surface emissivity and the velocity of air across the surface. Higher emissivity results in lower resistance.
- Higher air velocity produces lower resistance.
- In the case of air the effect is most noticeable at low velocities, from still air up to about 15 mph.

- The total resistance to heat flow across the frame and glass area of a window is the sum of the inside surface to air resistance, the resistance of the frame and glass itself, and the outside surface to air resistance. The reciprocal of the sum of these resistances is the conductance.
- Unit air to air heat conductance is called heat transmittance.
- It is the heat which is conducted through one square foot of window area in one hour when the temperature difference across the window is one degree Fahrenheit. This is written as BTU/hr/sq ft/°F and is referred to as the U-factor.

- The most effective and economical way to reduce conductive heat flow through glazed areas is to use double instead of single glazing.
- Double glazing will have about twice the resistance to heat flow as single glazing and can therefore cut energy losses almost in half.
- Double glazing requires the use of two panes of glass with an air space in between. It can be accomplished with secondary windows, dual sash, or sealed insulating glass, depending on the requirements of the building.
- Triple glazing will generally result in even greater savings but is more expensive, so the added cost will have to be weighed against the savings.

- Values for conductive heat transmission, or U-factors, for windows can be determined by the test method described in AAMA 1503-98
- Convective losses are caused by air moving across the surfaces of the window. Steps can be taken to minimize losses due to this air motion.
- On the outside, glass which is set back from the exterior surface of the wall will be more protected from the wind than glass which is flush with the exterior surface.
- Outside screens also help.

- On the inside, venetian blinds, roller shades, shutters, or drapes can be effectively used to reduce convective losses.
- Normally such interior devices depend on the proper use by occupants to achieve the best energy efficiency.

- Clear glass is transparent to most of the solar radiation that strikes it.
- The relatively short wave radiation passes through the glass and strikes the walls, floors, ceilings, and furnishings in a room where the solar energy is absorbed and reradiated as long waves.
- The radiation from inside the room is absorbed by the glass and re-radiated.
- The net effect, often referred to as the greenhouse effect, is to trap heat in the room.

- Heat gain from solar radiation can be both an advantage and disadvantage. The building orientation, window usage in each wall, external shading provisions, and choice of glass can all help to maximize the advantage and minimize the disadvantage of solar heat gain.
- Solar heat gain through the windows during the winter season contributes significantly to the heating requirements of the building and reduces energy required for heating by gas, oil or electricity. In this respect, windows in a well-designed, appropriately oriented building will perform as passive solar collectors.

- The disadvantages associated with solar radiation have to do with excessive heat, an extra air conditioning load, undesirable glare, and fading of furnishings.
- These disadvantages can be minimized through good designs which include protection from the sun through fixed and movable shading devices. This is discussed in more detail in the section on shading.

- Disadvantages can also be minimized through the selection of the proper glass. Tinted and reflective glass is available over a wide performance range. These glasses reduce the transmittance of solar heat and light.
- Reflective glass or external solar screens with clear glass will stop a major portion of solar radiation from entering a building and in so doing will significantly reduce the load on the air conditioning system and increase energy savings.

- Air leakage can be the cause of a major loss of energy. Cold winter air leaking in through windows requires heat to reach room temperature. The heat required to raise the temperature is known as *sensible heat*.
- Cold winter air does not contain much water vapor so that when it is heated to room temperature the relative humidity often drops to uncomfortable levels. To raise the humidity level it is necessary to use heat to evaporate water into the interior spaces. The heat required to evaporate water is known as *latent heat*.

- The sensible heat required to raise the temperature of air entering the building because of undesirable leakage through windows causes an undesirable loss of energy.
- If the building has controlled humidity, this undesirable energy loss is compounded.
- In air conditioned buildings during the summer month's the temperature of the air and the humidity level both must often be lowered. This puts an additional load on the air conditioning system to remove the sensible and latent heat from the air.

- Air leakage can therefore be a major cause of energy loss in the summer as well as winter.
- Under certain conditions the annual energy loss due to air leakage may approach the energy loss due to conduction.
- Tight tolerances, good seals, and careful installation are essential to the control of air leakage.

Shading

- Shading is one of the oldest methods used for protection against the hot summer sun.
- Overhangs can be provided and designed so that the sun cut-off angle on a southern exposure, for example, will permit the rays of the winter sun to enter while cutting off the warm summer rays.

- Exterior solar screens, blinds, awnings, and fixed or movable horizontal or vertical exterior louvers may be used.
- The use of exterior shading is an excellent way to protect against solar radiation because it prevents the radiation from passing through the glass and heating the interior.

- Many architectural windows are available today which provide a very happy compromise between exterior louvers or blinds and interior venetian blinds.
- These are double glazed windows in which a venetian blind is located between the inner and outer panes of glass.
- This arrangement is more effective than the interior blind because it stops the direct solar radiation before it passes through the inner glass pane.
- Since it is enclosed, it is protected from damage and requires minimum maintenance.

- The ratio of radiation which passes through a shaded opening to the radiation which would pass through the same opening with 1/8 inch clear glass, is known as the *shading coefficient*.
- Solar Heat Gain Factors are multiplied by the Shading Coefficients of the glass and shading devices to determine the heat transmission through the window. Typical shading coefficients are shown in Table 1.

Table 1. Typical Shading Coefficients

Material	Shading Coefficient
Clear Glass, 1/8 inch	1.00
Reflective glass, 1/4 inch	0.70
Venetian blinds, medium; 1/4 inch glass	0.64
Drapes, closed weave; 1/4 inch glass	0.35-0.45

- Reflective glass effectively reduces solar heat gain and daylight levels within a building; but it should be noted that in doing so, it reduces the potential benefit of solar heat gain entering the building during the wintry weather season.
- Also, it may reduce day lighting to a level at which more electric lighting is required.
- Additionally, this type of glass may reflect heat and light back into a nearby building and create a problem.

Condensation

- In the colder parts of the county, condensation on interior surfaces can be a serious problem under certain conditions of outside temperature and inside relative humidity.
- Insulating glass went a long way toward solving the problem for glass many years ago.
- More recently excellent methods have been found for breaking the thermal path through the aluminum framing from the inside air to the outside air.

- Windows incorporating both an insulating glass construction and a thermal break framing system or a vinyl framing system may be designated "thermalized windows" provided their condensation resistance factors.

- A brief discussion of the mechanism of condensation will help in the understanding of this problem. Air is a mixture of gases and one of the gases present in all but completely dry air is water vapor.
- Water vapor in the air is referred to as *humidity*.
- For any given temperature and atmospheric pressure there is a maximum amount of water vapor that air can hold. This is the *saturated state*, and air in this state has a *relative humidity* of 100%.

- Relative *humidity* is the ratio, expressed as a percent, of the amount of water vapor actually in the air to the maximum amount of water vapor the air could hold at a specific temperature and pressure.
- Warm air can hold considerably more *water vapor* than cold air.
- For example, the amount of *water vapor* in the air for 30% relative *humidity* at a temperature of 68°F would be the same amount which would produce 100% relative *humidity* at 35°F.
- At any temperature lower than this the air could no longer hold all of the *water vapor* and condensation would occur. The temperature at which condensation will occur is called the *dew point*.

- Any time the temperature of the inside surface of the window glass or the aluminum framing elements drop below the dew point, *condensation* on these surfaces will occur.
- The *condensation* will appear as moisture if the surface temperature is above freezing. If it is below freezing it will appear as frost.

- Figure 8 shows the relative humidity and inside surface temperature at which *condensation* will occur.
- Curves of this type for other conditions can be developed from standard charts.

Figure 8. Relative humidity and surface temperature at which condensation will occur.

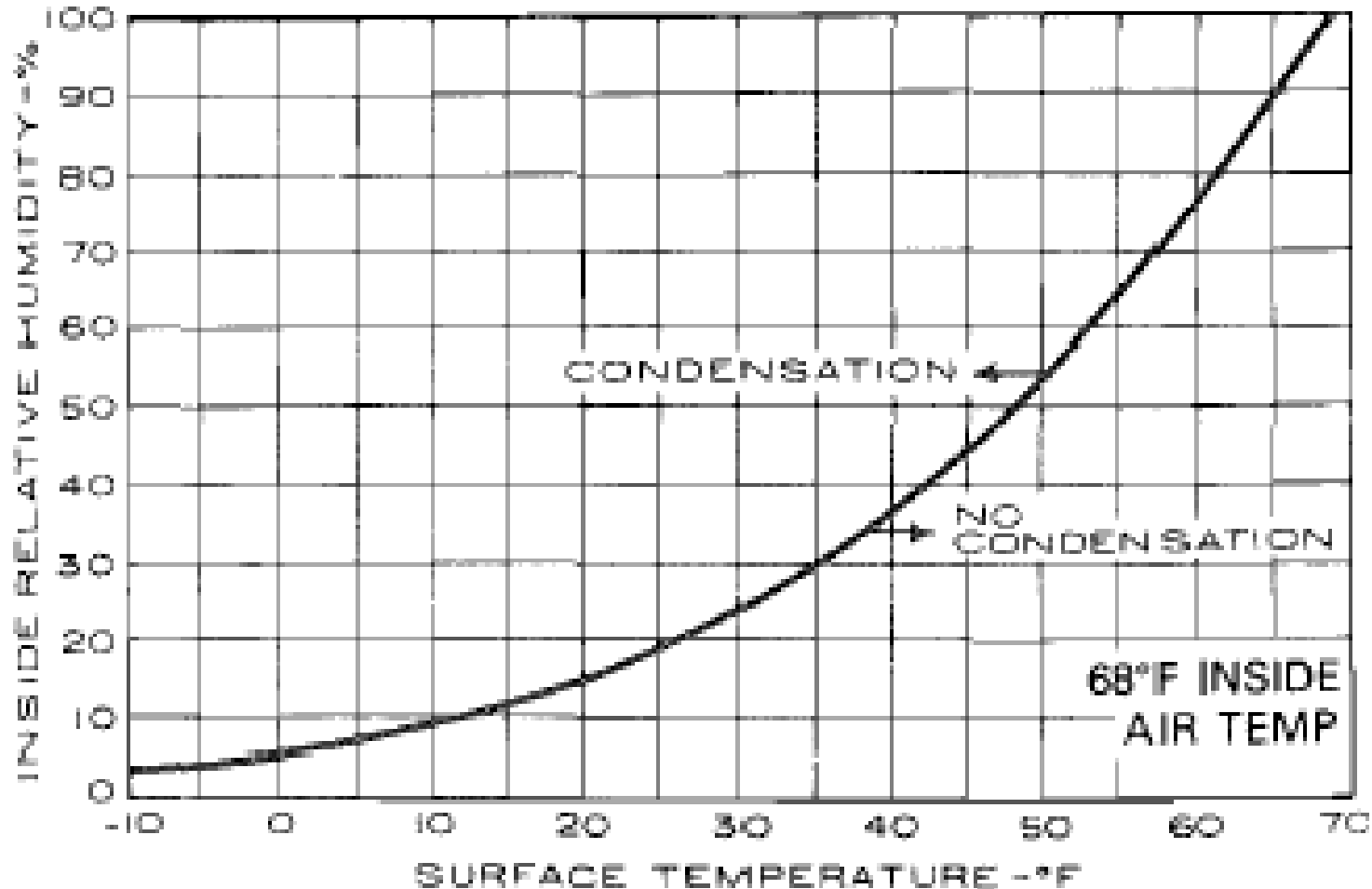

- To evaluate a window's resistance to condensation, the laboratory test method described in AAMA 1503.1-98 may be used to determine a **Condensation Resistance Factor (CRF)**.
- In this test method, temperatures are measured at a number of specified points on both the frame and the glass.
- An average surface temperature for both the glass and frame are found. Using these average temperatures the **CRFs** of the frame and glass are calculated.
- The lower of the two **CRFs** is the rating given to the window assembly.

Temperature data for specific locations are given in Chapter 33, *Weather Data and Design Conditions*, *ASHRAE Handbook of Fundamentals*, published by:

American Society of Heating, Refrigerating and Air-Conditioning Engineers, Inc.

Daylighting

- Daylighting in the building does provide benefits to the occupants.
- It enhances the performance of the tasks for which the building was designed without full dependence on artificial lighting.

- Control of lighting, protection from direct sunlight, avoidance of the glare distribution of light over the working plane are matters to which the designer should give much attention.
- The designer has a number of options at his disposal.
- These include window size, spacing and location.

- To optimize a design, Daylighting and *solar heat gain* must be considered together.
- To control heat gain so that it is beneficial while at the same time providing desirable Daylighting requires a well- thought-out selection of glasses and shading devices.

Sound

- Jet aircraft, densely traveled highways, city traffic ... all the marvelous modes of modern transportation create noise which is disturbing and distracting, if not debilitating, to occupants of buildings in the vicinity of such sources of sound.
- Windows have often provided the paths of least resistance for the transmission of airborne noises.

- Sound transmitting properties of windows must be determined by careful laboratory testing. From test data, the performance of a window under noisy conditions can be determined.
- Selection of glass is important.
- Two panes of glass separated by air are *superior* to a single pane.
- Thicker glass resists better than thinner glass.
- A three-inch air space between panes will have more "Sound Transmission Loss, (STL)", than a one-inch air space.

- Outer and inner panes of different thicknesses may be better than the same thicknesses.
- **Tilting** one pane at an angle relative to the other pane transmits less sound than parallel panes.
- In fact, all of the features which give a window good resistance to water and air leakage also give it good resistance to sound transmission.

Table 3. Noise Levels

Apparent Loudness	Examples	dBA
Deafening	Threshold of pain	130
	Jet Aircraft	120
	Elevated train	120
	Thunder	120
Very Loud	Subway train	110
	Nearby riveter	110
	Noisy industrial plant	100
	Loud street noise	90
	Noisy office	80
	Vacuum cleaner	80
Loud	Average street noise	70
	Average office	60
	Congested department store	60
Moderate	Moderate restaurant chatter	50
	Average two-person conversation	50
	School classroom	40
	Private office	40
Faint	Bedroom	30
	Rustling leaves	20
Very faint	Normal breathing	10
	Threshold of audibility	0

Table 4.
Range of
acceptable
sound levels
for building
interiors.

Type of Area	Sound Level dBA
Churches and schools	
Sanctuaries	25-35
Libraries	35-45
Schools and classrooms	35-45
Laboratories	40-50
Hospitals and clinics	
Private rooms	30-40
Wards	35-45
Lobbies and waiting rooms	40-50
Residences	
Private homes (rural and suburban)	30-40
Apartment houses	35-45
Private homes (urban)	35-45
2- and 3-family units	35-45
Hotels	
Individual rooms or suites	35-45
Ball rooms	35-45
Banquet rooms	35-45
Lobbies	40-50
Offices	
Conference rooms	30-40
Executive office	35-45
Supervisor office	35-50
General open offices	40-55
Drafting rooms	40-55

- In an effort to simplify this procedure a method was developed that provides a single number rating system for a product. This rating system is described in ASTM E 413-04 and is defined as the "Sound Transmission Class (STC)" of the product.

- Tables 5 and 6 respectively show values for sound reduction with single glass and with glass/air space combinations. The tables give an average STL, a percentage of loudness reduction compared to 1/4 inch glass and an STC rating. They provide general guidelines for glass selection.

Table 5. Sound reduction with single pane.

Glass Thickness		Average STL	Loudness Reduction	STC Rating
In.	mm	125-4000 Hertz	Compared to 1/4 inch glass	
1/10	2.5	23.5 dB	--	26
1/8	3	24.1 dB	--	29
1/4	6	26.5 dB	--	29
3/10	8	28.8 dB	15%	29
3/8	10	29.7 dB	20%	30
1/2	12	31.5 dB	29%	33
5/8	15	34.5 dB	42%	30
3/4	19	34.6 dB	43%	33
7/8	22	35.4 dB	46%	32

Table 6. Sound reduction with glass/air space combinations.

Glass Thickness						Average STL 125- 4000 Hertz	Loudness Reduction Compared to 1/4 Glass	STC Rating
No. 1		No. 2		Air Space				
in.	mm	in.	mm	in.	mm			
1/4	6	1/4	6	1/2	12	26.5 dB	--	29
1/2	12	1/4	6	2	50	38.1 dB	55%	39
1/2	12	1/4	6	4	102	39.3 dB	59%	40
1/2	12	1/4	6	6	152	40.0 dB	61%	42
3/4	19	3/8	10	6	152	40.6 dB	62%	40
1/2	12	1/4*	6	6	152	42.6 dB	67%	44
5/24	5	3/10	8	4	102	37.4 dB	53%	39
1**	25	1/4	6	6	152	40.4 dB	62%	40

*1/4-inch to .045 in. plastic (Laminated)

**1 in. Proprietary Insulated Glass Unit

Ventilation

- At one time, ventilation through windows was just as important a function as the provision for Daylighting.
- With the development of efficient central heating and air conditioning systems, reliance on windows for this function has diminished.
- In fact in many commercial buildings, such as high-rise structures, **windows are fixed** and ventilation is supplied entirely by the mechanical system.

- On the other hand there are many building types, such as schools, hospitals, small office buildings, residential housing, etc., which are located in parts of the country where **natural ventilation** through windows is desirable and economical during those days of the year when the temperature and weather are mild and pleasant.
- Under these circumstances **natural ventilation** will conserve energy.

- If windows are used for ventilation, building orientation relative to prevailing winds should be considered.
- Window sizes must be selected to provide adequate change of air for the volume of the building size.
- Ventilation through windows in case of mechanical breakdown, power failure or fire, is an important consideration.

Figure 10. Ventilation through projected windows.

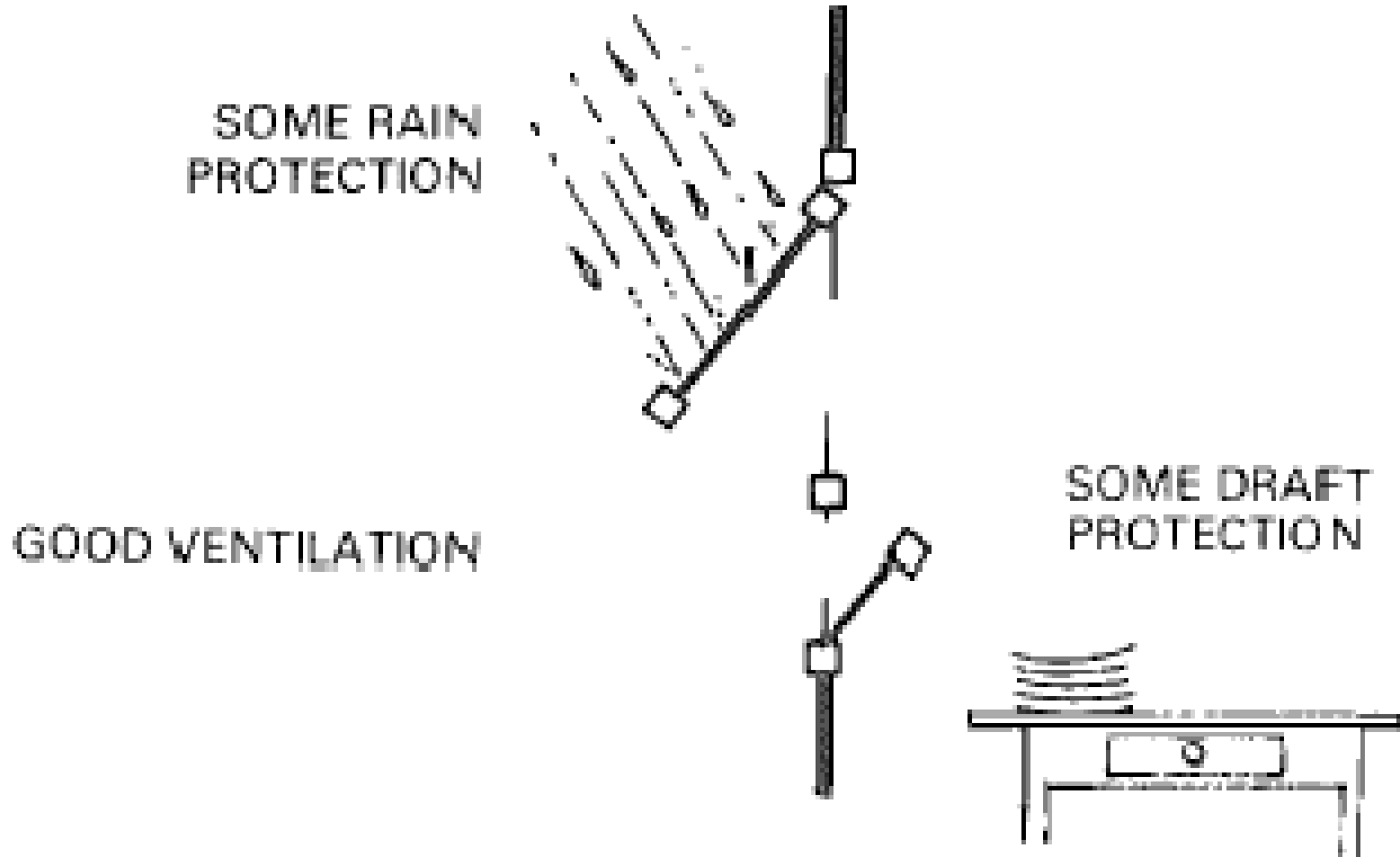

Operation

- The satisfactory operation of windows requires well-thought-out designs, careful material selection, good construction and appropriate hardware to the type of window specified.
- Horizontal sliding windows, hung windows, and vertical sliding windows operate within the plane of the wall.
- This requires that weather-stripping be tight, but not so tight that the window is physically hard to open.
- There is a limit to the force that a person can be expected to exert on a window in order to operate it.

- Not all operable windows are designed primarily to provide openings for natural ventilation.
- Vertically pivoted and top hinged In swinging windows are designed primarily to be opened so that the outside surfaces can be safely washed from the inside.
- However, designs are available with hardware which will permit the building occupants to open these windows safely with a limited amount of travel.

- Protection of building occupants from rain, heat, cold, insects, vandals, etc" is a basic function of the total window system.
- The window, when closed, must have adequate strength to resist wind loads and must properly seal to prevent wind and water penetration.

Safety

- Safety receives more consideration in today's building designs than it has in years past.
- In case of fire, operable windows may be opened to let deadly smoke and gases escape and permit life-preserving air to enter! Some window designs operate automatically.
- Most deaths occur in fires because of suffocation, not because of burning.
- Windows close enough to the ground provide a means of escape from a fire.

- Windows also provide a means of ingress for firemen. Adequate provision for this final contingency may conflict with the requirement to resist break-in by vandals.
- The use of high-impact resistant glazing to resist break-in must be accompanied by special design features which allow it to meet fire protection requirements. For specific information on this subject reference should be made to NFPA 101, Life Safety Code.

Economics

- The initial cost of the window plus maintenance must be measured against the savings in electric power which will be realized over the life of the building.
- On south facing windows there will be a beneficial solar heat gain during the winter heating season. This reduces the energy required for heating and windows should be given credit for these savings.

References

- **(AAMA) American Architectural Manufacturers Association**
1827 Walden Office Square, Suite 550
- Schaumburg, Illinois, PA. 60173-4268
- Phone: 847-303-5664 Fax: 847-303-5774

- **ANSI/AAMA/WDMA/CSA 101/I.S.2/A440-08,**
Voluntary Specifications for Aluminum and Poly
(Vinyl Chloride) (PVC) Prime Windows and Glass
Doors

- **ANSI/AAMA 1002.10-93**, Voluntary Specifications for Insulating Storm Products for Windows and Sliding Glass Doors
- **AAMA 502-08**, Voluntary Specification for Field Testing of Windows and Sliding Glass Doors
- **AAMA 902-07**, Voluntary Specification for Sash Balances
- **AAMA 910-93**, Voluntary 'Life Cycle' Specifications and Test Methods for Architectural Grade Windows and Sliding Glass Doors

- **AAMA 1503-98**, Voluntary Test Method for Thermal Transmittance and Condensation Resistance of Windows, Doors and Glazed Wall Sections
- **AAMA TIR A10-00**, Wind Loads on Components and Cladding for Buildings Less Than 90 Feet Tall
- **AAMA CW#2-1979**, The Rain Screen Principle and Pressure Equalized Wall Design
- **AAMA CW #9-1976**, Design for Energy Conservation in Aluminum Curtain Walls
- **AAMA CW #11-1985**, Design Wind loads for Buildings and Boundary Layer Wind Tunnel Testing

- **(ASCE) American Society of Civil Engineers**
1801 Alexander Bell Drive
- Reston, Virginia 20191-4400
- Phone: 1-800-548-2723 Fax: 703-295-6222
- **ASCE 7-05**, Minimum Design Loads for Buildings and Other Structures
- **(ASHRAE) American Society of Heating, Refrigerating and Air Conditioning Engineers, Inc.**
1791 Tullie Circle, NE Atlanta, GA 30329-2305
Phone: 404/636-8400 - Fax: 404-321-5478
– **ASHRAE Handbook of Fundamentals**

- **(ASTM) American Society for Testing and Materials**
ASTM International
 - 100 Barr Harbor Drive
 - P.O. Box C700
 - West Conshohocken, Pa. 19428-2959 USA
 - Phone: 610-832-9500 – Fax: 610-832-9635
 - **ASTM E 283-91 (1999)**, Standard Test Method for Determining the Rate of Air Leakage Through Exterior Windows, Curtain Walls and Doors Under Specified Pressure Differences Across the Specimen

- **ASTM E 330-02**, Standard Test Method for Structural Performance of Exterior Windows, Curtain Walls and Doors by Uniform Static Air Pressure Difference
- **ASTM E 331-00**, Standard Test Method for Water Penetration of Exterior Windows, Curtain Walls and Doors by Uniform Static Air Pressure Difference

- **ASTM E 413-04** Classification for Rating Sound Insulation
- **ASTM E 547-00**, Standard Test Method for Water Penetration of Exterior Windows, Curtain Walls and Doors by Cyclic Static Air Pressure Differential
- **ASTM E 1332-90 (re-approved in 2003)**, Classification for Determination of Out-Indoor Transmission Class

(NFPA) National Fire Protection Association
11 Tracy Drive
Avon MA. 02322
Phone: 617-770-3000 - Fax: 617/770-0700

ANSI/NFPA 101-09, Life Safety Code

(NBS/NIST) National Bureau of Standards Department of the National Institute of Standards and Technology

100 Bureau Drive

Stop 1070, Gaithersburg, MD 20899-1070

Phone: 301-957-6478 Fax: 301-957-8295

Questions?

Robert Tellez
Roberts Consulting Group
San Diego, Ca. 91941
1-619-713-2024
www.RobertTellez.com